

# Bucher XPowa V120t road

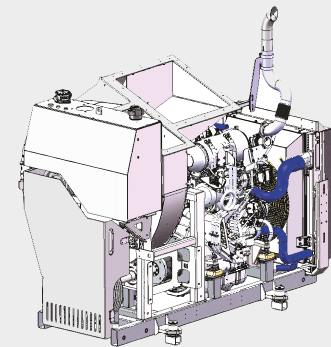
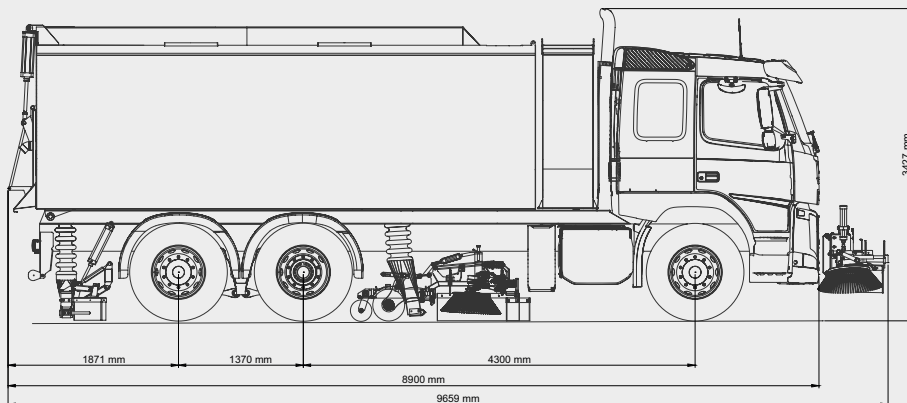

## Dimensions

Length	8900 mm
Width	2550 mm
Height	3427 mm
Wheelbase	4300 mm
Max. cleaning (simult. sweep)	3500 mm

## Power pack

High capacity fan	4 cylinder - 129 kW
Power output	129 kW @ 2050 rpm
Max torque	690 Nm
Fuel consumption*	5 - 20 l/h*

\*In normal sweeping mode 7.5 l/h

## Driving Performance

Working speed*	0.5 - 12 km/h
Travelling speed	0 - 90 km/h

\*Depending on gearbox selection

## Chassis

Volvo	FM 460 6x2
GVW	26000 kg
Empty weight	16800 kg
Payload	8400 kg

## Volvo crawler gears

Crawler gear 1 (ratio)	32:1
Crawler gear 2 (ratio)	19:1 DD* / 17:1 OD*
Reverse gear (ratio)	37:1

\*DD: Direct-drive / OD: Overdrive

## Designed for the most demanding cleaning requirements.



### High capacity fan

High performance & payload. Low fuel consumption and noise level.



### Side sliding brush unit

Sweep at a distance by extending the brush and suction nozzle.



### Complete control

Adjust your sweeping equipment with the ergonomic, built-in panel.



### Rear suction

Optimal surface cleaning with minimal water spillage.

# Bucher XPowa V120t road

## Hopper

Each hopper is made up of three primary parts: the engine cowl, the hopper body and the integral water tanks.

Voided air volume	12 m <sup>3</sup>
Water volume with rear suction	3320 L
Tipping angle	40°

## Water tank

The Bucher XPowa V120t road has two water tanks located on either side of the hopper for optimum weight distribution and balance. An extra watertank is added behind the cab to give you additional 1,500 litres .

## Power pack

The high capacity fan allows for operation at low revolution, precisely at the optimum torque curve, resulting in a low fuel consumption and very low noise level

## Controls

Adjust every part of your equipment with the ergonomically built-in sweeping controls located in the cab.

## Sweep gear

Optimum brush set up designed to withstand the most arduous conditions and suit all of your application needs.

Centre brush	Fixed / pivoting
Channel brush	Dual, side sliding and simultaneous sweeping
Brush behind	Behind suction nozzle

## Water system

High pressure	200 bar @ 106 l/min
Spray bar	V-jets, right side
Behind standard suction	
Spray bar	4 V-jets, right side
Fitted at brush unit	

## Rear suction / Rotor jets

The full width rear suction offers you optimum surface cleaning and increased surface friction levels, providing safer driving conditions. Side suction pods minimise the spill of water. As an option, we offer rotor jets for superior results in deep cleaning.

## Options

- Side sliding front brush 750 mm
- Heat exchanger (Nordic) for standard water system
- Front-mounted spray bar for standard water system
- 4 nozzles to clean hopper
- Spray bar in front of wide suction with rotating nozzles
- Spray bar behind standard suction with V-jets, left side
- Spray bar incl. 4 V-jets, fitted at brush unit, left side
- Tool box
- Central lubrication
- Separate fuel tank for auxiliary engine

Contact us for more information.

*Subject to change without notice.*



**Bucher Municipal A/S**  
Lillehøjvej 15  
DK-8600 Silkeborg  
Tel. +45 8682 1211  
info.dk@buchermunicipal.com

www.buchermunicipal.com



Bucher  
Municipal  
E-Shop

**Driven by better**