

Bucher MaxPowa V80 rear suction

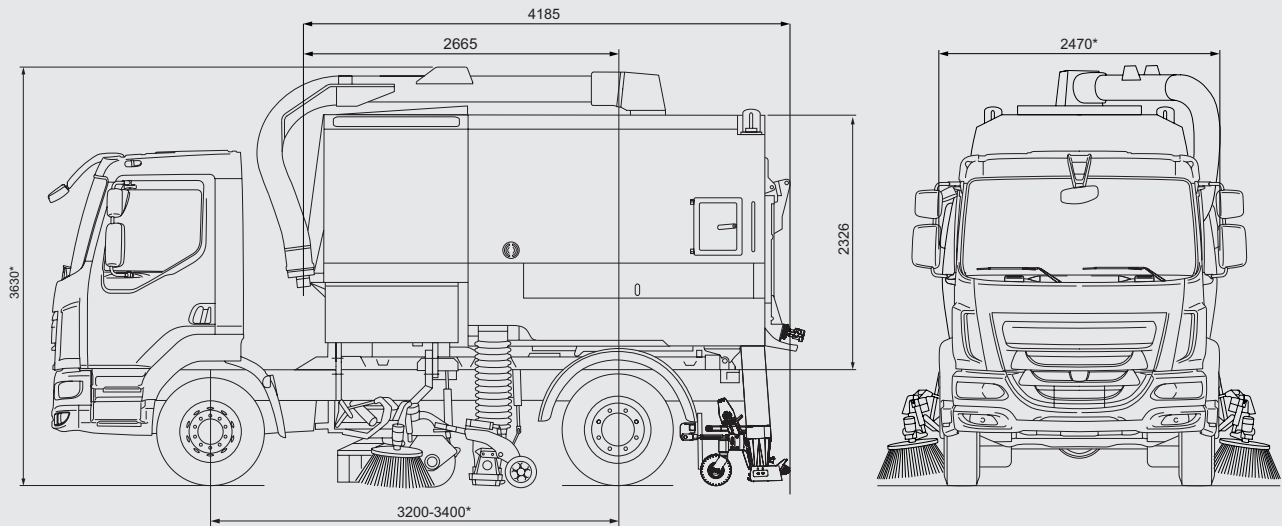

Dimensions

Length (cowl and hopper)	4185 mm
Width*	2470 mm
Height*	3630 mm
Wheelbase*	3200-3400 mm nominal
Sweeping path of suction nozzle and channel brush	1300 mm
Sweeping path with roller brush	2400 mm
Sweeping path for double-sided pick up	3600 mm
Cleaning path for rear nozzles	2500 mm

Noise level cab

<75 dB(A) generally
(dependent on chassis selection)

Alternative drives

Hydrostatic V80h

Chassis

GVM 18 tonnes

Diesel fuel tank

Capacity (up to 190 l with Stage 3a) 170 l

Auxiliary engine

	V80t
Standard:	JCB Dieselmax 448 NRMM Stage 5
Gross power	97 kW @ 2200 rpm
Max torque	550 Nm @ 1500 rpm
Option:	JCB Dieselmax 444 NRMM Stage 3a**
Gross power	85 kW @ 2200 rpm
Max torque	440 Nm @ 1300 rpm

* Dependent on chassis and/or option selected
** Not for EU. 24v only

Features



Heavy-duty
corrosion resistant body, including 1.4301 stainless steel integral water tank.

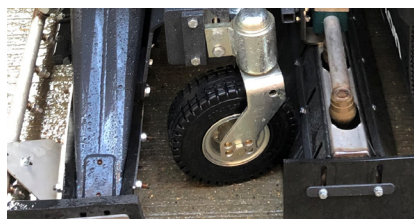

16 Rotating jets
optional rotating jets for high intensity cleaning in front of the rear nozzles, when in combination with Powawash.



Rear Suction Nozzles
high performance pickup available with or without additional high pressure Powawash option.

Bucher MaxPowa V80 rear suction

Controls

Centre cab mounted master control panel with JVM providing information on a wide range of sweeper functions plus data capture download. Separate palm rest controller housing controls for the main sweeping functions is mounted on the door side. Electronic water valves for in-cab control of Powawash options with a dedicated keypad for quick and easy operation.

Exhauster fan

Operational speed variable between 1800 rpm - 3500 rpm to suit operation. V80t: Step-up gearbox ratio: 1.79:1

Channel brush

Quick release brush system with infinitely variable speed up to 160 rpm (cab controlled). Hi-visibility yellow brush plate and hose guide.

Water tank

1.4301 stainless steel water tank, anti-surge baffles and filled via a type 'A' water hydrant fill. A twin diaphragm pump runs continuously and is able to run dry.

Water capacity	2300 l
Water capacity (Powawash opt.)	1700 l
Water capacity (Max)	4000 l

Dust suppression system

Dust suppression sprays located at suction nozzle(s), channel brush(es) and across front of vehicle. Pressadrain water purging system. EUnited PM10 4* Certified. V jet spraybar as standard when in combination with Powawash option.

Electrical system

24 volt. All external loom connections are full automotive IP67 rated.

Exterior noise / Sound power level

LWA 112 dB(A) for high power engines measured in accordance with EC directive 2000/14/EC.

Hopper

Body comprises of hopper & integral water tank. Fabricated from heavy duty stainless steel plate. Water tight twin lock rear door latching system with de-watering function. Two body side access doors and side storage lockers. Plug in hopper floor as transfer port for use as Streetwasher. Rear discharge chute, automatic multi position body prop, twin caged rear beacons and LED worklights are standard features.

Hopper voided volume ***	8.0 m ³
Discharge angle	56° nominal
Door opening angle	125° nominal

Nozzle

Cast aluminium nozzle with 250 mm diameter inlet and tool free adjustment.

Rear nozzles

Full width mild steel rear nozzles. Three heavy duty 250mm dia castor wheels.

Cowl

Smoothflow cowl lined with frequency matched soundproofing material.

Brushes

Wide sweep brush	Ø 406 mm
Width of wide sweep brush	1275 mm
Width of suction nozzle	750 mm
Channel brush (opt. Ø710mm)	650 mm

Options

- Camera monitoring systems.
- Littasnatch.
- Powathrust/Powasave.
- Powascrub - wide sweep brush ground pressure device.
- Powawash - high pressure washing system, 120 l/min @ 160 bar, c/w 1700 l auxiliary water tank.
- 6" or 8" boom mounted Wanderhose with power assist option.
- Rotating jets, in front of rear suction nozzles.
- Bitumen lined hopper water tank (for high chloride water areas).
- Additional fuel tank - 200 l (ESU only)

*** All Bucher Municipal Hopper Capacities are measured in accordance with European Standard EN 15429

Bucher Municipal



For local contact and support, please scan the QR code or visit

buchermunicipal.com

Driven by better



Bucher Municipal
E-Shop

Version 04_09/2021
Technical data is subject to change without prior notice.
The illustrations may deviate from standard equipment.